

## BKI SPARE PARTS LIST

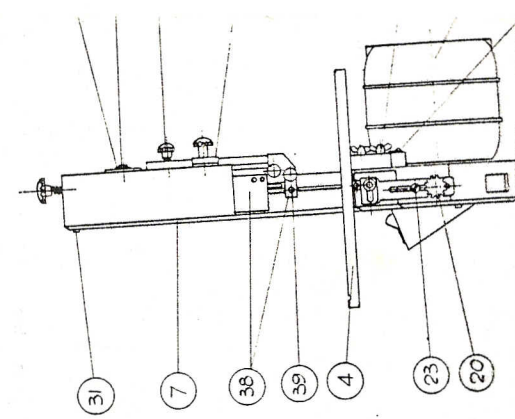

Key	Reference Number	Description	Key	Reference Number	Description
1	019730	Frame	25	012400	Switch
2	010103	Pointer	26	012500	Switchbox
	010104	Screw } Set	27	012600	Screws (3)
3	010206	Centre plate	28	012801	Cable (UK only)
4	010207	Table and centre plate	29	012900	Cable clamp and screws (2)
5	019738	Base plate and feet		250150/1	Cable clamp and screw (1)
6	010302	Rubber feet	30	013100	Terminal block
	010303	Screws } Set (4)	31	013402	Quick release cover screw
7	019731	Cover plate		013403	Washer
8	019732	Motor (220/240v - 50Hz)	32	013701	Motor screws
	019756	Motor (100v - 50Hz)	33	013900	Stud (4)
	019757	Motor (100v - 60Hz)	34	014100	Wing nut (2)
	019758	Motor (110v - 50Hz)	35	014300	Cam
9	010704	Nylon wheel	36	019733	Frame and base complete
10	010802	Nylon drive wheel		014508	Blade 8 t.p.i.
11	010905	Timing pulley		014514	Blade 14 t.p.i.
	010906	Roll pin } Set		014524	Blade 24 t.p.i.
12	011001	Timing belt		014532	Blade 32 t.p.i.
13	011100	Top wheel casting assembly		014538	Blade 3/4" 6 t.p.i.
14	011106	Securing bolt		015100	Fence
15	011108	Wheel shaft (3)		016000	Instructions
16	011109	Circlip (3)	37	010104	Cable clamp screws
17	011110	Washer	38	019500	Upper blade guide assembly
18	011111	Locknut	39	019503	Guide blocks (Set 4) and centre plate
19	011200	Tension knob assembly	40	019620	Bearing shaft
20	011211	Securing knob			Bearing } Set
21	011300	Tracking knob assembly			Circlip
22	019739	Blade shield clamp	41	019600	Lower Blade guide assembly
23	012000	Bolt	42	019621	Roller
24	012206	Lock washer (Set 2)			Roll pin } Set
			43	019606	Lock nut

To obtain any spares listed above please quote exact ordering reference numbers